

Dear customer, thank you very much for buying this Phocos product. Please read the instructions carefully and thoroughly before using the product. It comes with a number of outstanding features, such as:

- Case protection: IP68 protection, in 1.5 m water depth 72 Hours.
- Dimming function
- Control unit (CU) to configure CIS charge controller via infra-red data link
- External temperature sensor for temperature compensation of charge voltages
- Widely programmable
- 3 stage charging (boost, equalization, float) for flooded battery, 2 stage charging (boost, float) for sealed battery
- Automatic recognition of system voltage 12/24 V

Safety Features

	Solar terminal	Battery terminal	Load terminal
Reverse polarity	Protected (1)	Protected (1)	Protected (2)
Short circuit	Protected	Protected (3)	Switches off immediately
Over current	N/A	N/A	Switches off with delay
Reverse current	Protected	N/A	N/A
Over voltage	Max. 55V (4)	Max. 40V	Switches off above 15.5V / 31.0V
Under voltage	N/A	N/A	Switches off
Over temp.	Reduces the charging current by PWM if over temperature occurs and switches off the load if the temperature reaches a high level.		

- (1) Controller can not protect itself in a 24V system; Upanel-Ubattery is limited to 40V.
 - (2) Controller can protect itself, but loads might be damaged.
 - (3) Battery must be protected by fuse, or battery will be permanently damaged.
 - (4) The solar panel voltage should not exceed this limit for a long time as voltage protection is done by a varistor.
- WARNING: The combination of different error conditions may cause damage to the controller. Always remove the error before you continue connecting the controller!

Low Voltage Disconnect Function (LVD)

- State of charge (SOC) controlled: Disconnect at 11.00V/22.00V to 11.70/23.40V(SOC1), 11.12V/22.24V to 11.76/23.52V(SOC2), 11.25V/22.50V to 11.83/23.63V(SOC3), 11.38V/22.72V to 11.89/23.78V(SOC4), 11.51V/23.02V to 11.96/23.92V(SOC5), 11.64V/23.28V to 12.02/24.04V(SOC6) .
- Voltage controlled (LVD): Disconnect at a fixed voltage between 11.0/22.0V and 11.9/23.8V (Step 0.1V).

Factory Settings

You can configure CIS charge controllers via the Control Unit (CU). See CU manual for details.

	Factory setting
Load mode	Standard controller
Low voltage disconnect	SOC4
Battery type	Sealed
Dimming value	50 %

Liability Exclusion

The manufacturer shall not be liable for damages, especially on the battery, caused by use other than as intended or as mentioned in this manual or if the recommendations of the battery manufacturer are neglected. The manufacturer shall not be liable if there has been service or repair carried out by any unauthorized person, unusual use, wrong installation, or bad system design.

Technical Data

Nominal voltage	12/24 V, automatic recognition
Boost voltage	14.4/28.8 V (25 °C), 2 h
Equalization voltage	14.8/29.6 V (25 °C), 2 h
Float voltage	13.8/27.6 V (25 °C)
Load disconnect voltage	11.00-12.02 V/22.00-24.04 V By SOC 11.0-12.0 V/22.0-24.0 V By voltage
Load reconnect voltage	12.8/25.6 V
Evening hours /Morning hours	0-15 hours / 0-14 hours
Dimming value	0...100 % output power
Dimming output voltaLge	0 V to 5 V relative to battery minus
Night/day detect	2.5-10 V
Battery type	Flooded, Sealed
Temp. compensation	-4.2 mV/K per cell
Max. solar current	5/10/20, According to model number @ 60 °C
Max. load current	5/10/20, According to model number @ 60 °C
Dimensions	82 x 58 x 20 mm
Wire size	CIS05: 1.5 mm ² ; CIS10: 2.5 mm ² ; CIS20: 4 mm ²
Typical power consumption	Lower than 8/10mA
Ambient temp. range**	-40 to +60 °C
Case protection	IP68 (1.5 m, 72 h)
Max altitude / Weight	4000 m / 150 g

** : At 60 °C CIS can only have full current on panel or load, not together.

Connecting and Grounding

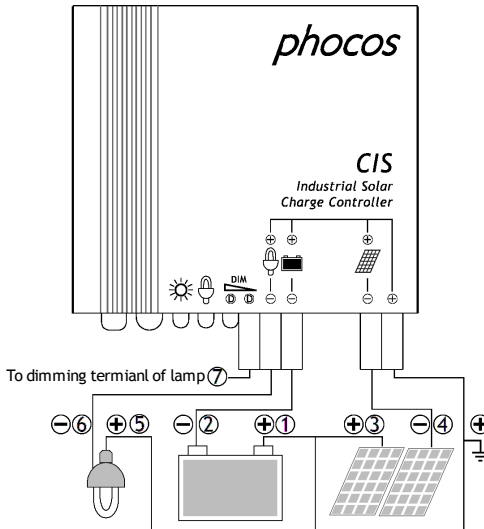

- Connect wires in order indicated 1 2 3 4 5 6 7 to avoid installation faults.
- To avoid any voltage on the wires, first connect the wire to the controller, then to the battery, panel or load.
- Recommended minimum wire size: CIS05: 1.5 mm²; CIS10: 2.5 mm²; CIS20: 4 mm².
- Make sure the wire length between battery and controller is as short as possible.
- Be aware that the positive terminal of CIS are connected together and therefore have the same electrical potential. If any grounding is required, always do this on the positive wires.

Display & Warning Functions

LED	Status	Function
	On	Controller connected to battery, night detected
	Flash	Controller connected to battery, day detected
	Off	No battery connected
	On	Load low/high voltage disconnect(LVD/HVD)
	Flash	Load over current
	Off	Load OK
	On	Dimming because of LVD/HVD
	Off	Time controlled dimming
All LED	Green-->Red-->Green-->	Programming

Night-Light Function

The CIS controller comes with a sophisticated night-light function. It controls the load output at night and is widely programmable. There are 3 modes available: Standard Controller, Dusk to Dawn and Evening/Morning modes.

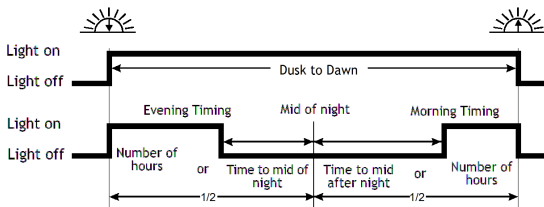

"Middle of night" is detected automatically as the midpoint between dusk and dawn, no setting of a clock is required. It may take several days until the controller has "learned" the middle of the night precisely. "Middle of night" may be different from 12:00 midnight depending on your location. The controller recognizes day and night based on the solar array open circuit voltage. This day/night threshold can be modified according to local light conditions and the solar array used.

Testing Function

Pushing the test button on the CU (Control Unit) will switch on load terminal for 2 minutes. If pressing the button causes a load disconnect event (LVD/SOC, over current) the load will be switched off.

亲爱的用户：非常感谢您选用伏科产品！在使用本产品前，请仔细阅读本手册。新一代的 CIS 控制器，是一款根据最新技术标准开发的，代表最新工业水平的产品。此产品拥有许多卓越的特征：

- 防护等级：IP68，在 1.5 m 水深承受 72 小时不损坏。
- 输出功率在 0.....100%可调。
- 控制器本身无任何按键，通过遥控器 (CU) 设置。
- 外置温度补偿传感器，测量环境温度更准确。
- 先进的可编程功能，可灵活定时夜间照明时间。
- 三阶段充电控制 (强充，均衡充，浮充)。
- 12/24 V 系统电压自动识别。

接线和接地

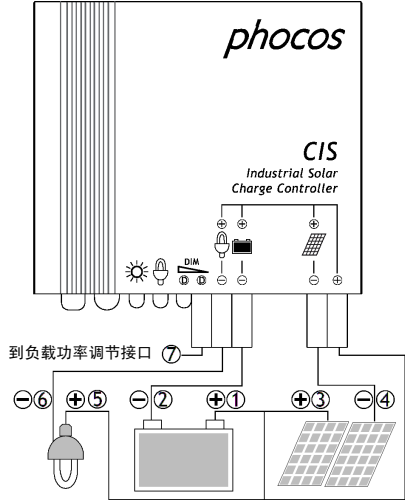

- 按照图中数字标出的连线顺序把控制器连接到您的太阳能系统中。
- 为了避免电缆上的电压，请首先连接控制器端，然后是蓄电池、太阳能电池板和负载。
- 推荐线径：CIS05: 1.5 mm²; CIS10: 2.5 mm²; CIS20: 4 mm²。
- 确保蓄电池和控制器之间的电缆长度尽可能短，防止电缆上的压降过高引起的控制器误判。
- 控制器为共正极设计。因此如果系统需要接地，只允许正极接地。

显示和报警功能

LED 灯	状态	功能
	点亮	蓄电池连接到控制器上，时间为夜晚
	闪烁	蓄电池连接到控制器上，时间为白天
	关闭	没有连接蓄电池
	点亮	负载低压切断或高压保护
	闪烁	负载过流
	关闭	负载正常
	点亮	输出功率调节功能启动
	关闭	负载额定功率运行
所有 LED 灯	循环点亮	编程中

路灯功能

CIS 控制器具有先进的路灯控制功能。负载点亮的时间和方式都可以根据客户需要灵活的编程。有 3 种模式可供选择：
通用控制器、黄昏到凌晨和夜晚/清晨方式。

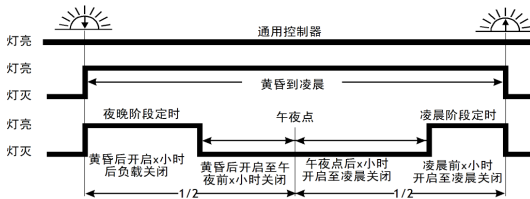

“午夜点”的确定，控制器会根据实际的黄昏与凌晨的持续时间，自动识别中间点，也就是控制器认为的午夜点，不需要用户设定真正的时间。控制器自动确认准确的午夜点需要几天时间的运行。这种方式可能在某些时候不太准确，但是可以避免用户在不同的季节对时钟进行校核。控制器确定的午夜点与实际时间的午夜是不相同的。
控制器通过测量太阳能电池的开路电压，识别白天和黑夜。根据所处不同地区和不同太阳能电池板，用户可以自行设置不同的光控点电压（白天和黑夜的临界电压）。

测试功能

在遥控器 (CU) 上，有一测试按键 (Test)。按此按键可将控制器的负载端打开 2 分钟。在白天，CIS 的测试功能可以帮助判断系统安装是否正确，也可以帮助排除故障。在这 2 分钟内，用户可以通过再次按测试键关闭负载。
如果按编程按钮打开负载后，导致系统进入 LVD (放电保护) 状态，负载会自动关闭。当系统处于 LVD 状态时，测试功能不可用。

安全特性

	太阳能端	蓄电池端	负载端
极性反接	保护 (1)	保护 (1)	保护 (2)
短路	保护	保护 (3)	立即切断
过流	N/A	N/A	延时切断
反向充电电流	保护	N/A	N/A
过压	最高 55 V	最高 40 V	大于 15.5 V/31 V 切断
欠压	N/A	N/A	切断负载
过温	当温度过高时，控制器会用 PWM 方式限制充电电流；如果温度达到一定的高度，控制器会切断负载。		

- (1)、在 24 V 系统中，如果蓄电池端或太阳能端有一端极性反接就可能损坏控制器。
- (2)、控制器可以保护自己，负载很有可能已经损坏。
- (3)、我们强烈建议在蓄电池和控制器之间接上保险丝，否则蓄电池会永久性损坏。
- (4)、太阳能端电压不能长时间高于 55 V，因为在太阳能端是靠变阻器分压实现保护功能的。
警告：两个或两个以上的不同的错误条件同时存在很有可能损坏控制器，所以在继续下一步操作前，首先要先排除现有故障。

低压切断功能(LVD)

- 蓄电池电量方式(SOC)控制：断开负载在 11.00 V / 22.00 V 至 11.70 / 23.40 V (SOC1)，11.12 V/22.24 V 至 11.76/23.52 V (SOC2)，11.25 V/22.50 V 至 11.83/23.63 V (SOC3)，11.38 V / 22.72 V 至 11.89 / 23.78 V (SOC4)，11.51 V / 23.02 V 至 11.96 / 23.92 V (SOC5)，11.64 V / 23.28 V 至 12.02 / 24.04 V (SOC6)。
- 蓄电池电压(LVD)控制：切断负载电压固定值，11.0 / 22.0 V 至 11.9 / 23.8 V。(精度 0.1 V)
注释：斜线前后的数值分别代表在 12 V 和 24 V 系统中的电压值。

出厂设置

	出厂设置
负载控制方式	通用控制器
低压保护方式	SOC4
蓄电池类型	胶体蓄电池
输出功率	50 %额定功率

免责声明

生产商不承担，由于违反本手册建议或提及的规范，以及忽视蓄电池生产商的建议而造成的任何损失。如果有由非指定人员提供维修服务、不正常使用、错误安装或者错误的系统设计情况出现，生产商不承担任何责任。

技术参数

额定电压	12/24 V，自动识别
强冲电压	14.4/28.8 V (25 °C)，持续 2 小时
均衡充电电压	14.8/29.6 V (25 °C)，持续 2 小时
浮充电压	13.8/27.6 V (25 °C)
低压切断电压	11.00-12.02 V/22.00-24.04 V 电量控制 11.0-12.0 V/22.0-24.0 V 电压控制
负载再连接电压	12.8 / 25.6 V
夜晚/凌晨运行时间	0-15 小时 / 0-14 小时
额定电压	12/24 V，自动识别
输出功率调节范围	0...100 % 负载功率
功率调节端子输出电压范围	0 --- 5 V (相对于电池负极)
白天/黑夜识别电压范围	2.5-10 V
蓄电池类型	胶体，液体
温度补偿系数	-4.2 mV/K per cell
最大充电/负载电流	5/10/20 A，由型号确定 @ 60 °C
尺寸/重量	82x58x20 mm (w x h x d) / 150 g
推荐线径	1.5 mm ² 5 A ; 2.5 mm ² 10 A ; 4.0 mm ² 20 A
自消耗功率	低于 8/10 mA
工作温度范围**	-40 到 +60 °C
海拔高度/防护等级	4000 m/IP 68 (1.5 m , 72 h)

**：在 60 °C 时，只能在太阳能端或负载端一端满载运行。

如有更改，恕不另行通知。版本：20090629
在以下国家生产：
德国 - 中国 - 玻利维亚 - 印度
Phocos AG - Germany www.phocos.com
CID:181812420

ISO9001:2000

CE RoHS