

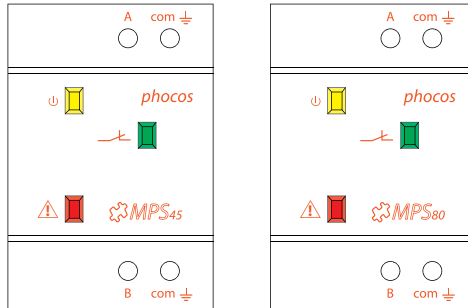

Modular Power Management Quick Start Manual

Components of the MPM System

MPS:
MPS45, MPS80,
MPS45-48V,
MPS80-48 V



MCU:

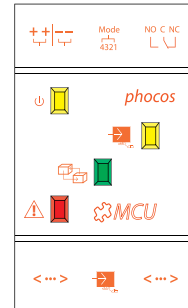

MPPT:
MPPT 100/30

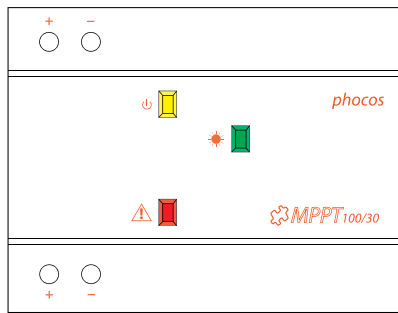

MXI:
USB



MXI 232:
RS232



MCS:



Modcom (PC Software):



MCS-Shunts:

MCS-SM 50/50
 MCS-SM 100/50
 MCS-SM 200/50



MCS-SM 400/50



MCS-SM 800/50

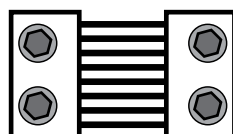

General Safety Information



This manual contains important, installation, set up and safety operating instructions.

Please read carefully the instructions and cautions in this manual before beginning with any installation.

Please do not disassemble or attempt to repair Phocos products. Phocos charge controllers do not contain user serviceable parts inside.

Please observe all instructions with regards to external fuses/breakers as indicated.

The information contained in this shall be observed in its full extent. Information regarding installation, set up operation is contained in it.

Please read this manual carefully before using the product and pay attention to the safety recommendations in it.

Maintenance and installing notes

Whenever installing or working on the PV system, please disconnect first the PV (solar) modules from the charge controller to prevent the charge controller to be damaged !

Please verify that all cable/wire connections are tightly fastened to the charge controller connectors / connecting posts in order to avoid any bad connections that may result in excessive heating from any loose connection.

Please install fuse or breaker near to battery before installing or adjusting the controller!

Please do not allow water to spill or flow into the charge controller. Please install and operate the controller in dry ambient.

Risks caused by high voltage

Operation of this appliance may produce a high voltage which may cause severe injuries or death in case of improper installation or operation of the appliance.

High DC Voltages are delivered by PV modules. Furthermore a nominal 48Vdc system will have PV panel open circuit voltages that may reach up to 100Vdc !

Risks caused by mains and charging current

Make sure cables are always connected to the correct terminal. An electrical shock may be lethal. In general any electric shock is dangerous to life and limb.

CE labeling

This appliance meets the requirements of the Low-Voltage-and Electromagnetic compatibility Directives and, therefore, is a CE-compliant product.

1. Quick Start Stand-Alone:

In standalone mode all devices are running independent from each other

1.1 MPS Stand-Alone

Multifunctional Switching Module with either Overcharge Protection or Low Voltage Disconnect for Stand-Alone Systems.

- Power Switch Functions
- Flexible Grounding

There are 3 possible applications for using the MPS as stand-alone unit:

- Using MPS as a photovoltaic charge controller
- Using MPS as a DC load switch for deep discharge protection
- Using MPS as a wind-/hydro generator charge controller (diversion control)

1.1.1 Overcharge Protection: PV Charger

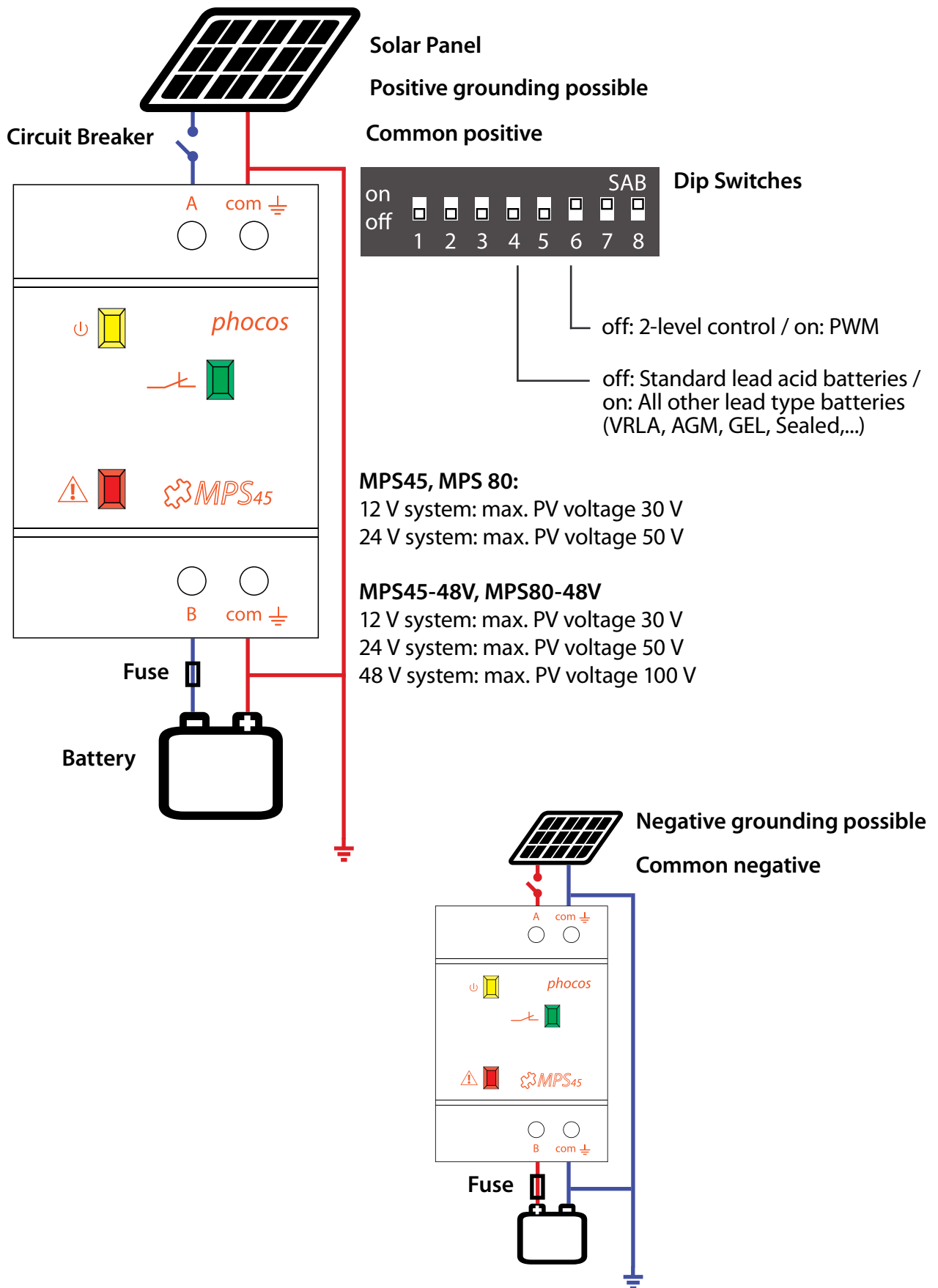

1.1.2 Deep Discharge Protection: MPS as Load Controller

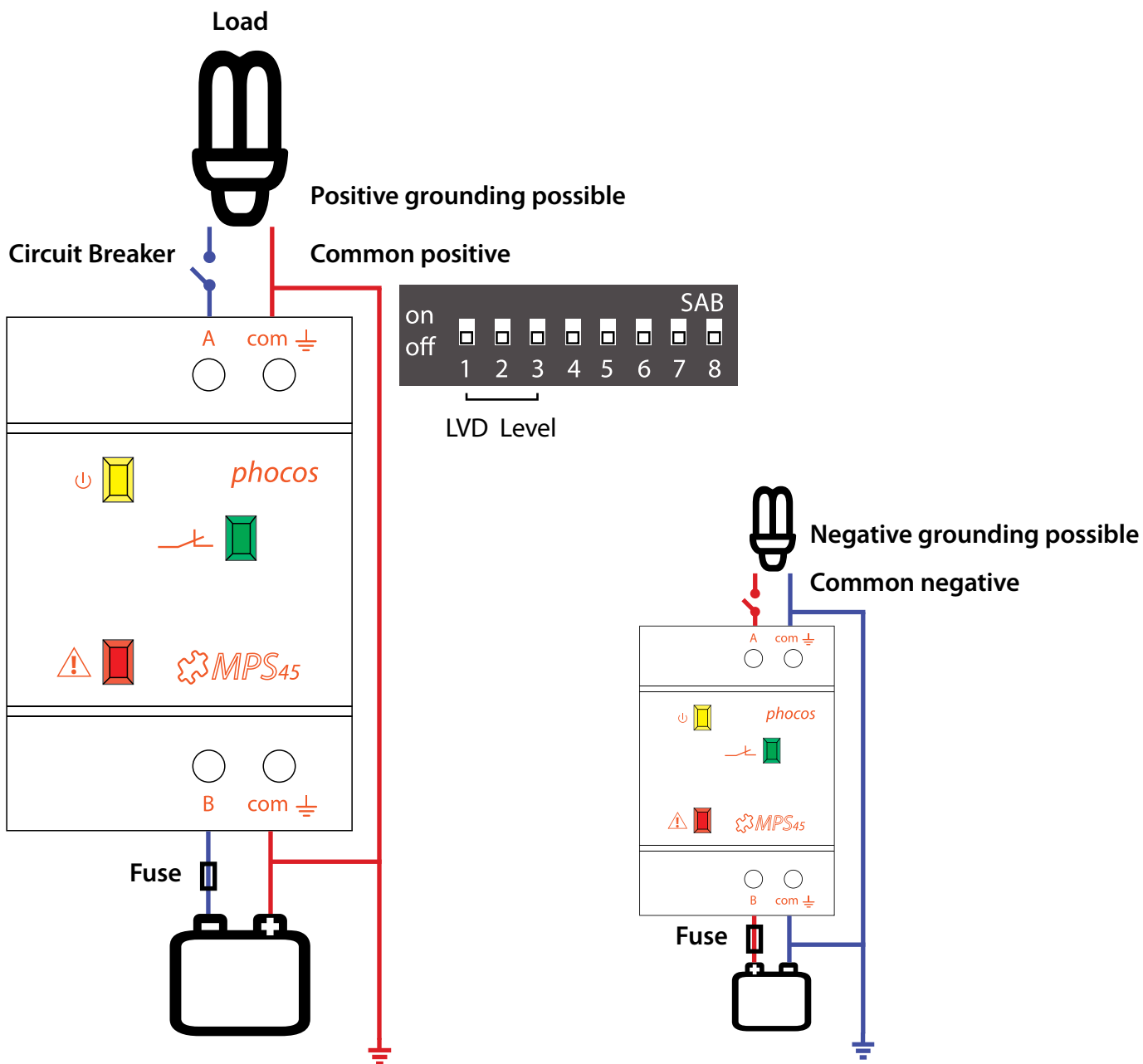

DIP 1	DIP 2	DIP 3	LVD level
OFF	OFF	OFF	Level 1 (11.0V, 22.0V, 44.0V)
ON	OFF	OFF	Level 2 (11.25V, 22.5V, 45.0V)
OFF	ON	OFF	Level 3 (11.5V, 23.0V, 46.0V)
ON	ON	OFF	Level 4 (11.75V, 23.5V, 47.0V)
X	X	ON	Level 5 (12.0V, 24.0V, 48.0V)

Fixed values in stand alone mode	12 V System	24 V System	48 V System
Low Voltage Reconnect	LVR = 12,8	LVR = 25,6 V	LVR = 51,2 V
High Voltage Disconnect	HVD = 15,5 V	HVD = 31 V	HVD = 62 V

1.1.3 Over Protection: Dump Controller

MPS can be used as diversion load switch that can direct excess energy to a diversion-load when the battery reserve is full. This prevents overcharging from inputs such as wind and micro-hydro turbines.

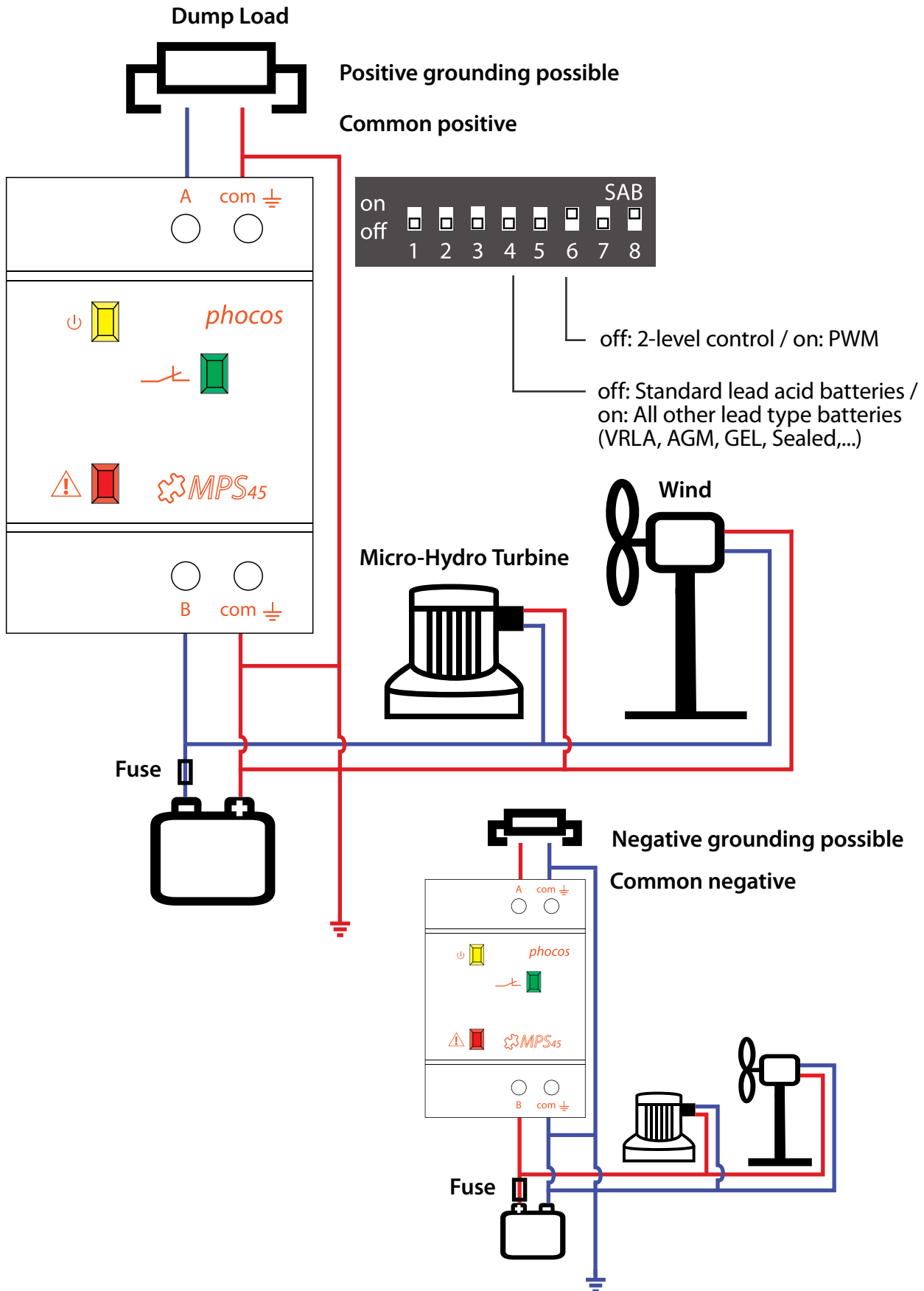

Dump Load calculation for systems with Wind - and Water - Generator

Recommendation for calculation of the Dump Load:

Please observe that the dimensioning of the minimum allowed Dump Load resistance is limited by the nominal current of the MPS45 / MPS45-48V respectively MPS80 / MPS80-48V. The rated current of the MPS should never exceeded by consideration of all tolerances of the Dump Load resistance.

Below you will find a list with the minimum allowed resistance and the accorded minimum power of the Dump Load which you could connect on the individual MPS type. You will find also the maximum power of the generator which you could use in such a system.

In any case of wrong calculation of the Dump Load Phocos takes no warranty!

Recommendations for the minimal allowed Dump Load resistance:

The Dump Load recommendation values are calculated by using following assumption:

				Unit
Battery-system voltage	12	24	48	Volt
Maximum battery voltage	15,0	30,0	60,0	Volt
Minimum end of charge voltage	13,0	26,0	52,0	Volt

Minimum Dump Load resistance recommendation MPS45/MPS45-48V:

Battery-system voltage	12	24	48	Volt
MPS45	x	x		
MPS45 - 48V	x	x	x	
Max current rating	45	45	45	Ampere
Recommended minimum Dump-Load Resistor value	0,39	0,75	1,5	Ohm
Minimum Power-rating for this Dump-Load Resistor	750	1500	2500	Watt
Maximum power of the generator for the minimum Recommended resistor value	430	900	1800	Watt

Minimum Dump Load resistance recommendation MPS80/MPS80-48V:

Battery-system voltage	12	24	48	Volt
MPS80	x	x		
MPS80 - 48V	x	x	x	
Max current rating	80	80	80	Ampere
Recommended minimum Dump-Load Resistor value	0,22	0,43	0,82	Ohm
Minimum Power-rating for this Dump-Load Resistor	1050	2100	4400	Watt
Maximum power of the generator for the minimum Recommended resistor value	750	1500	3200	Watt

1.1.4 MPS LED Troubleshooting

	RDY = Yellow LED	ON = Green LED	ERROR = Red LED
Bootloader (after bootloading)			
Data communication activ (bootloading) (only bus connected)	ON	Flashing	Flashing
Wiring check (wiring problem detected, error could only happen after start up)			
Voltage check failures (example: Voltage to high at load terminals)	Blinking	ON	OFF
Current check failures (example: no current at load/ dumpload or invers modul-current)	Blinking	OFF	ON
General indication (if error is eliminated MPS goes into normal operation mode)			
Connection lost (only bus connected)	Flashing	OFF	OFF
Error ‚Overcurrent‘	ON	OFF	ON
Error ‚Temperature‘	OFF	OFF	ON
Error ‚Overvoltage‘	ON	OFF	Blinking
Error ‚Bad Battery‘	ON	OFF	Flashing
Error ‚Different battery voltage to MCU‘ (only bus connected)	ON	Alternate Blinking	Alternate Blinking
Deep discharge protection			
Normal operation	ON	OFF	OFF
Load on	ON	ON	OFF
Load off	ON	OFF	OFF
Over charge protection			
Normal operation	ON	OFF	OFF
Switched on (Modul or Dump)	ON	ON	OFF
Switched off	ON	OFF	OFF
In PWM mode (Modul or Dump)	ON	Blinking	OFF

1.2 MPPT 100/30 Stand-Alone:

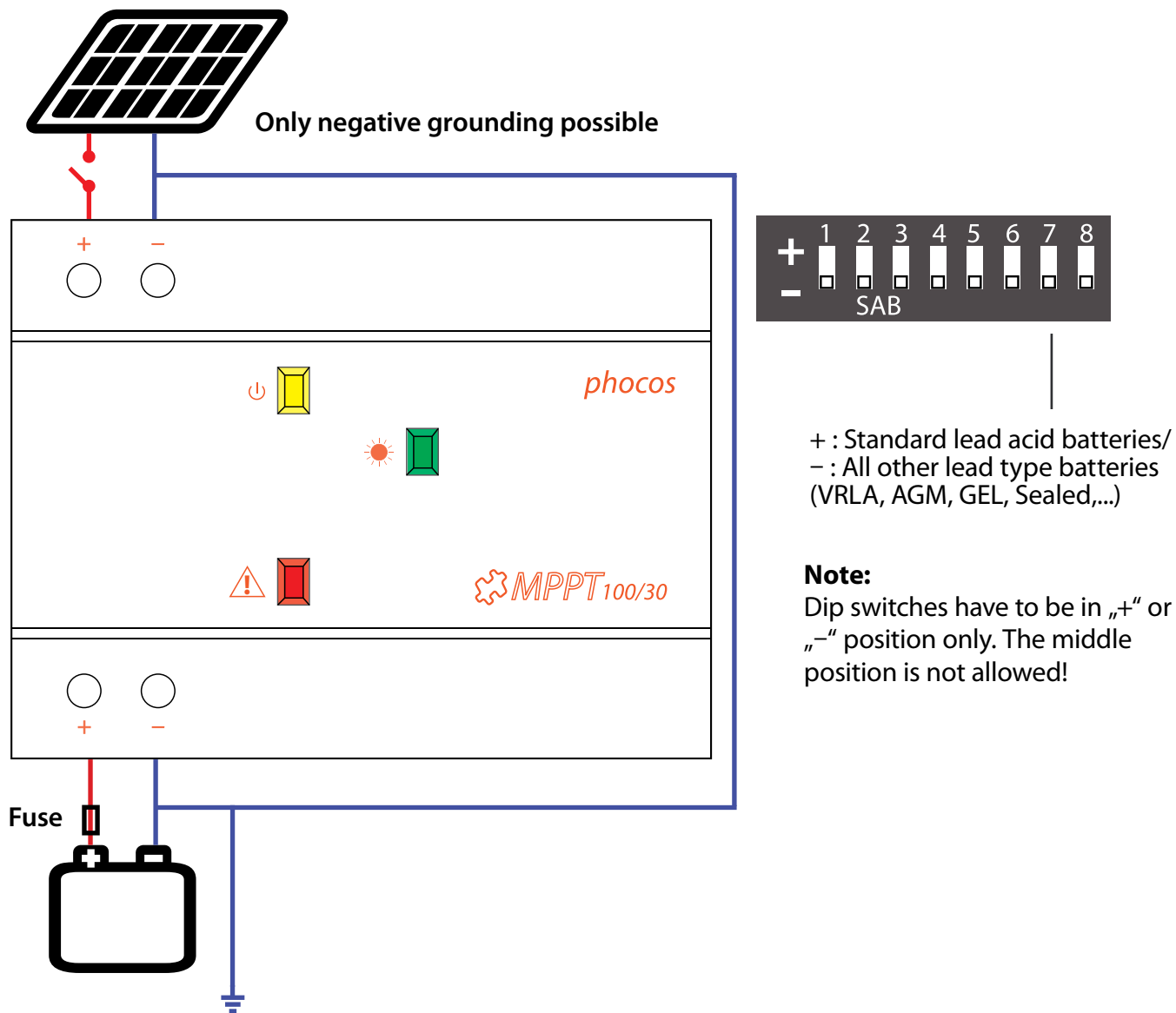

MPPT LED Troubleshooting

	RDY = Yellow LED	ON = Green LED	ERROR = Red LED
Normal charging	ON	ON	OFF
Sleep mode	ON	OFF	OFF
Errors			
Over temperature	ON	OFF	ON
Over current	ON	OFF	ON
Over voltage	ON	OFF	ON

2. Quick Start MCU Controller Mode

All devices have to be connected via bus cables. All devices are controlled via MCU. Therefore MCU controlled Mode gives an opportunity to customize each and all possible settings.

2.1 MCU Dip Switches

MCU-Dip 1

Dip- switch 1 is used for the system clock energy support selection

DIP 1:ON
MCU clock is supported by the internal coin cell



DIP 1: OFF
MCU clock is supported by the system battery



MCU-Dip 2 & 3

DIP-switch 2 and 3 are used for the system voltage selection

DIP 2 OFF and DIP 3 OFF:
12 V System voltage



DIP 2 OFF and DIP 3 ON:
24 V System voltage



DIP 2 ON and DIP 3 OFF:
48 V System voltage



MCU-Dip 4

DiP-switch 4 is used for battery type selection

DIP 4: ON
All other lead type batteries
(VRLA, AGM, GEL, Sealed,...)



DIP 4: OFF
Standard lead acid batteries



MCU LED Troubleshooting

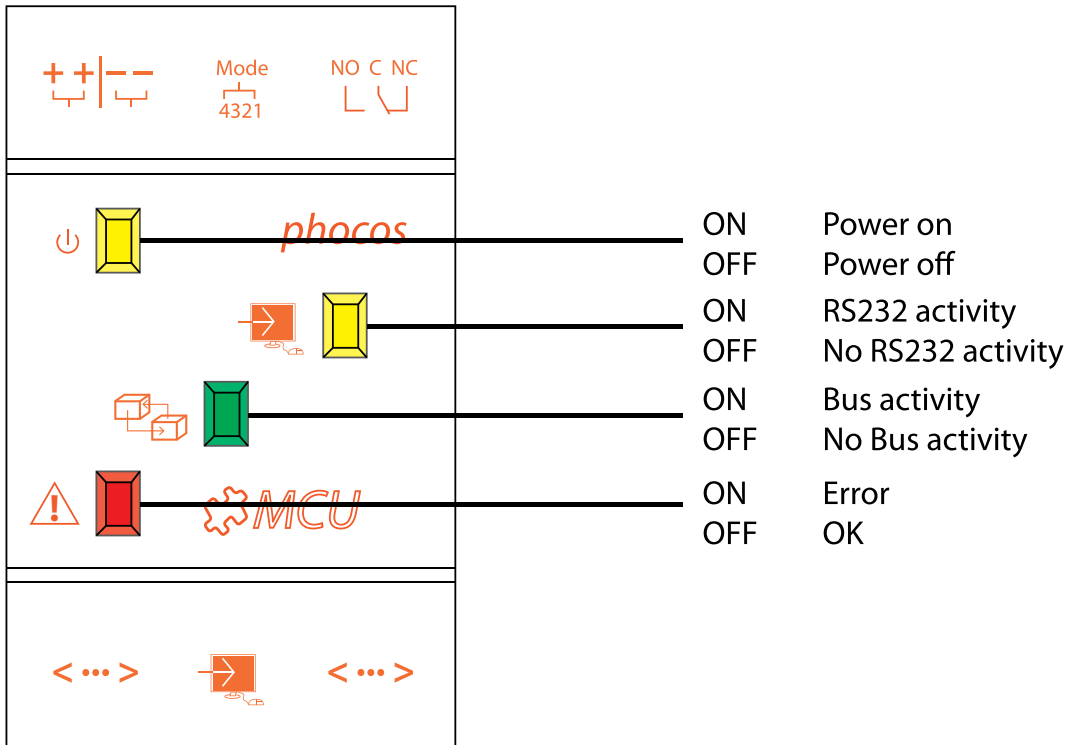

	Yellow LED (Power LED)	Yellow LED (RS232 LED)	Green LED (BUS LED)	Red LED (Error LED)
After startup	ON	OFF	10 s after restart LED is flickering	OFF
Normal Operating Mode	ON	OFF	Flickering	OFF
Communication over RS232	ON	Flickering	Flickering	OFF
Errors				
MCU Dip Switches in wrong position	1 Flash	OFF	OFF	ON
Different grounding	2 Flashes	OFF	OFF	ON
To many devices	3 Flashes	OFF	OFF	ON

2.2 MCU Controlled Mode: Device Dip Settings

Max. allowed devices in a system:

MPPT max. 8 devices

MPS for overcharge protection (Dip 8 ON) or MPS diversion loads (Dip 8 ON) max. 8 devices

MPS for discharge protection max. 8 devices

MCS max. 4 devices

MTS max. 1 devices

Maximum 16 devices total allowed

MPS Dip Switches

Overcharge Protection

PV-Controller



Address

(See table 2)

off: 2-level control / on: PWM

Dump-Controller (Diversion Load)



Address

(See table 2)

off: 2-level control / on: PWM

Deep Discharge Protection



Address

(See table 2)

MPPT Dip Switches



Address

(See table 3)

MCS Dip Switches

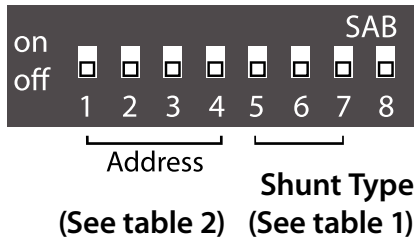

DIP5	DIP6	DIP 7	Shunt Type	Accuracy
OFF	OFF	OFF	50 A / 50mV	0-25 A 30 mA, 25-50 A 60 mA
ON	OFF	OFF	100 A / 50mV	0-50 A 60 mA, 50-100 A 120 mA
OFF	ON	OFF	200 A / 50mV	0-100 A 120 mA, 100-200 A 240 mA
ON	ON	OFF	400 A / 50mV	0-200 A 240 mA, 200-400 A 480 mA
N/A	N/A	ON	800 A / 50mV	0-400 A 480 mA, 400-800 A 960 mA

Table 1: MCS Shunt Type

MCS and MPS Address Table

Dip-Sw \ Address	0	1	2	3	4	5	6	7	8	9	10	11	12	13	14	15
1	OFF	OFF	OFF	OFF	OFF	OFF	OFF	OFF	ON	ON	ON	ON	ON	ON	ON	ON
2	OFF	OFF	OFF	OFF	ON	ON	ON	ON	OFF	OFF	OFF	OFF	ON	ON	ON	ON
3	OFF	OFF	ON	ON	OFF	OFF	ON	ON	OFF	OFF	ON	ON	OFF	OFF	ON	ON
4	OFF	ON	OFF	ON	OFF	ON	OFF	ON	OFF	ON	OFF	ON	OFF	ON	OFF	ON

Table 2: MPS, MCU Addresses

MPPT Address Table

Dip-Sw \ Address	0	1	2	3	4	5	6	7	8	9	10	11	12	13	14	15
1	-	-	-	-	-	-	-	-	+	+	+	+	+	+	+	+
2	-	-	-	-	+	+	+	+	-	-	-	-	+	+	+	+
3	-	-	+	+	-	-	+	+	-	-	+	+	-	-	+	+
4	-	+	-	+	-	+	-	+	-	+	-	+	-	+	-	+

Table 3: MPPT Addresses

2.3 Connecting MCU via MXI with Modem or PC

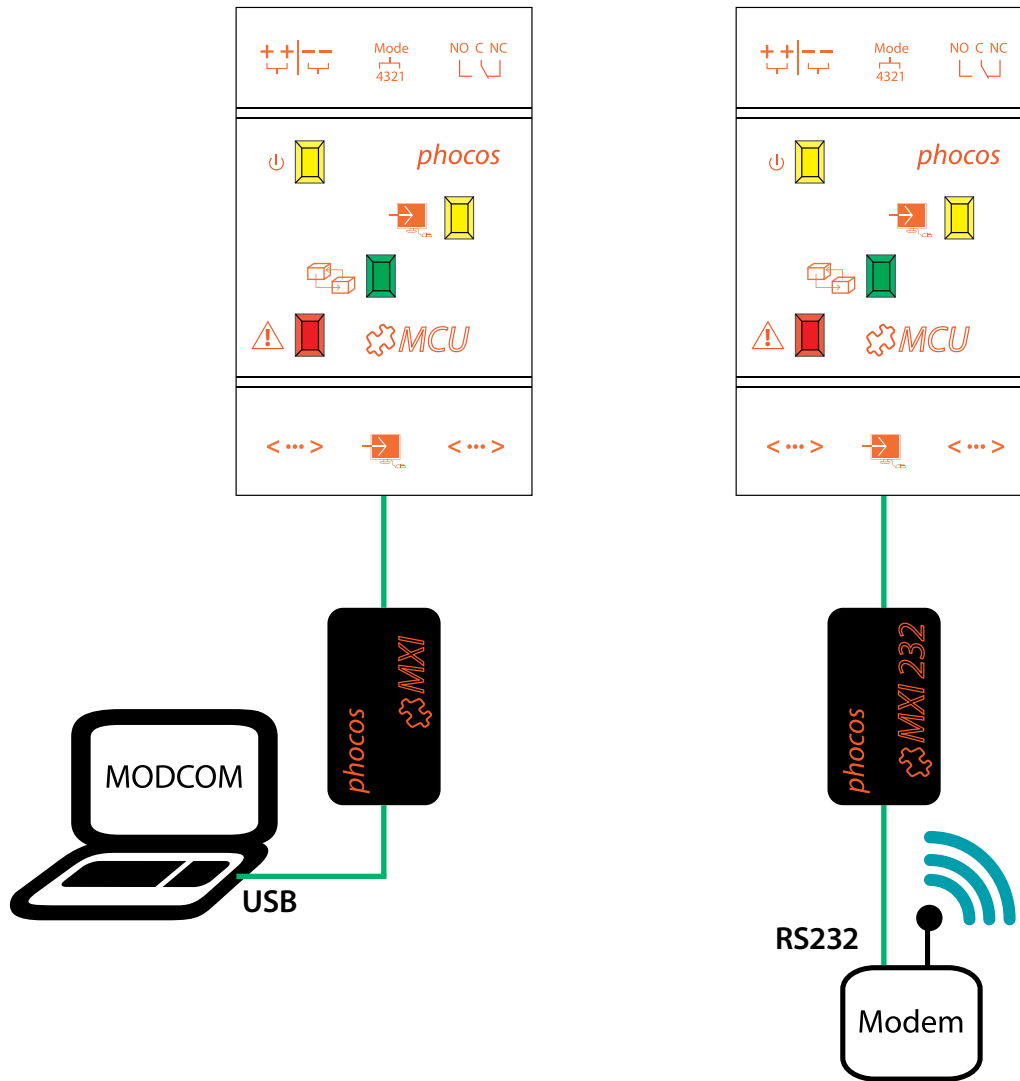

2.4 Connecting Battery and MTS with MCU

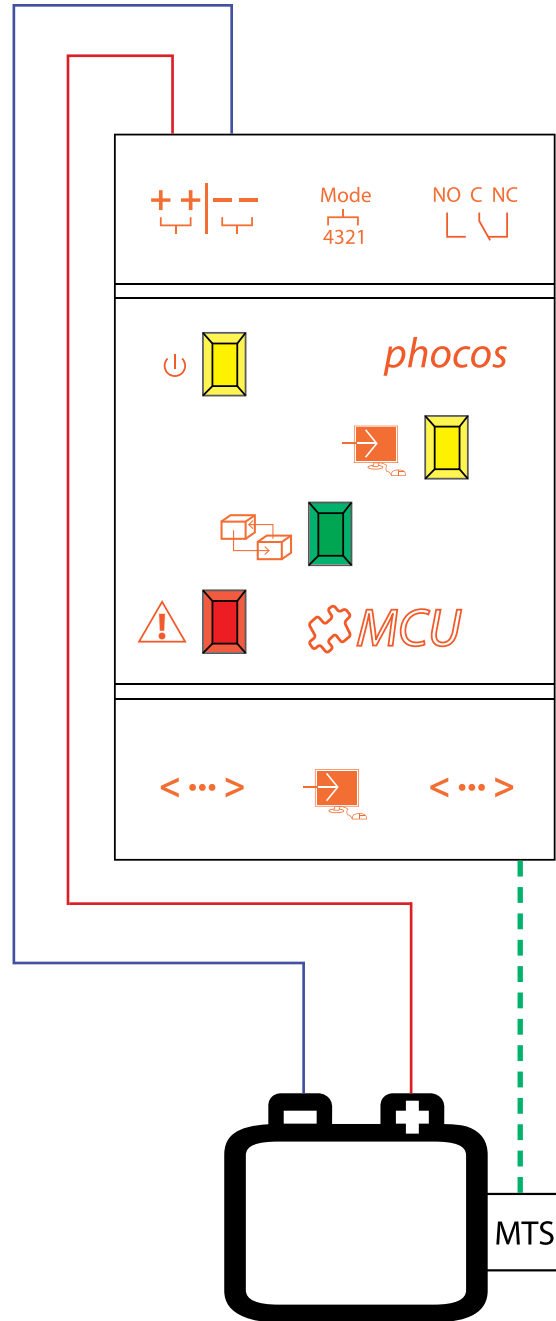

Example 2

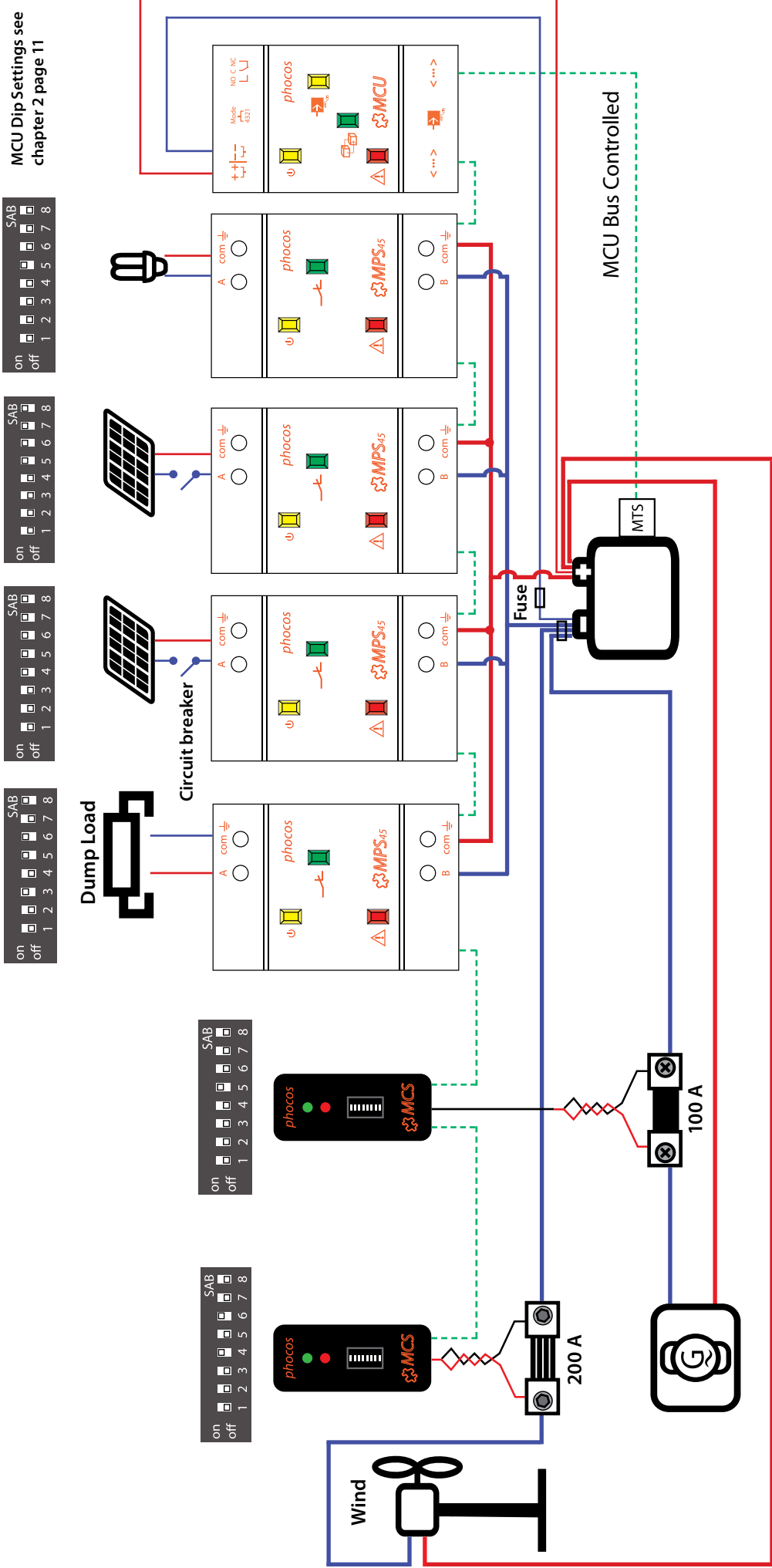

Common positive
Positive grounding possible

Example 3

1 2 3 4 5 6 7 8
 SAB

1 2 3 4 5 6 7 8
 SAB

1 2 3 4 5 6 7 8
 SAB

1 2 3 4 5 6 7 8
 SAB

on off

on off

on off

on off

MCU Dip Settings see chapter 2 page 11

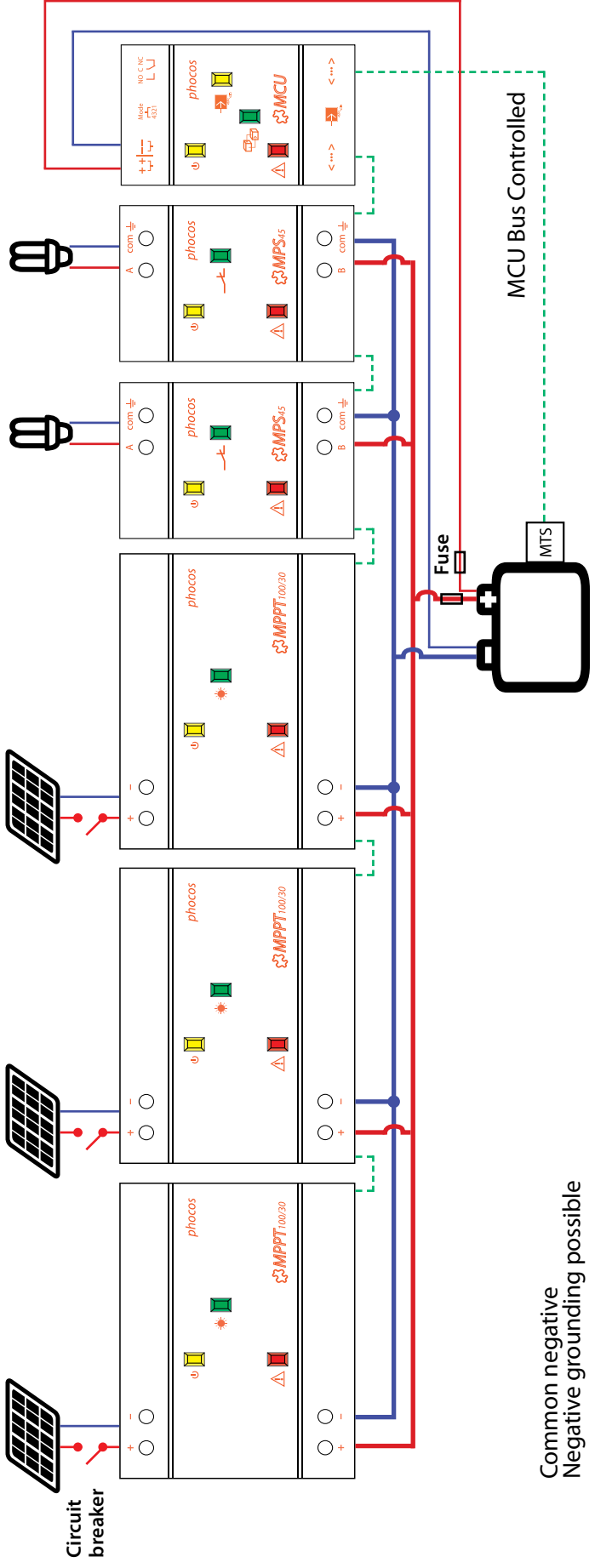

Common negative
Negative grounding possible

Example 4

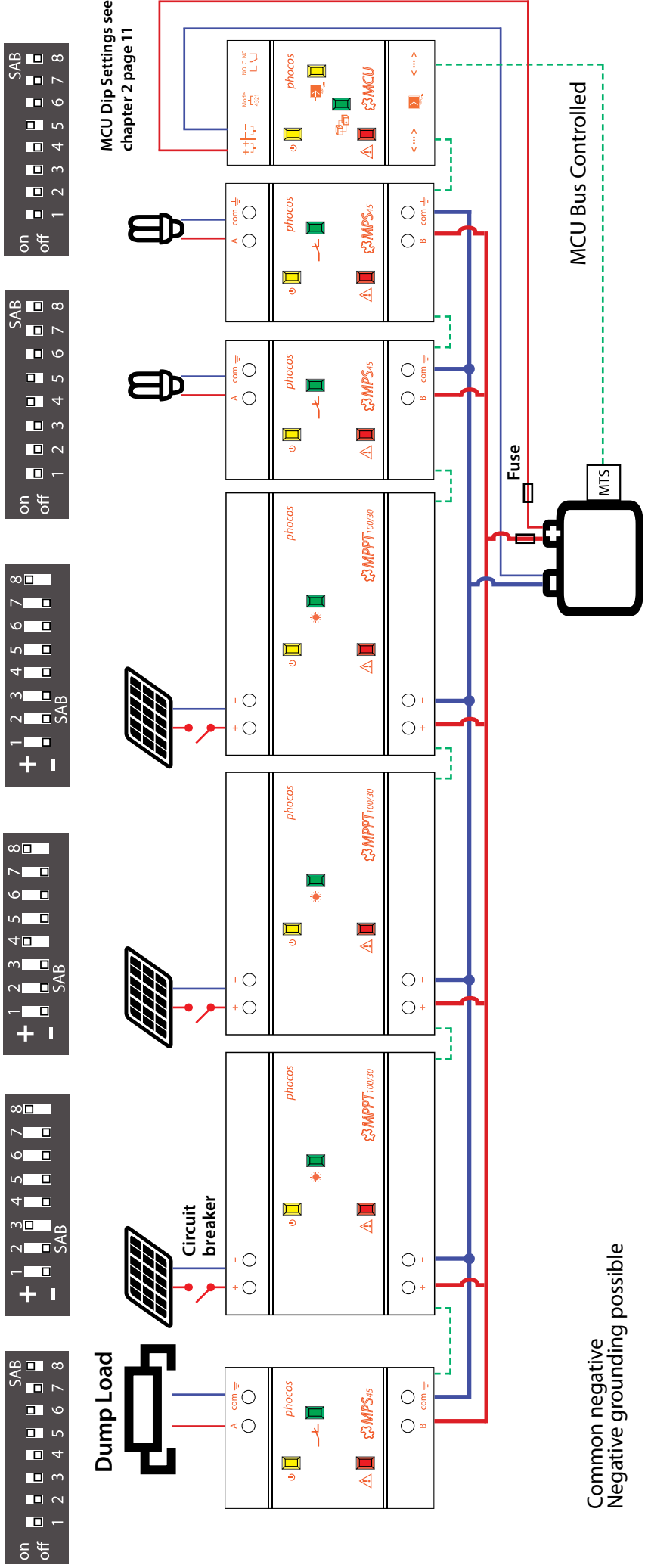

Phocos AG
Magirus-Deutz-Str. 12
89077 Ulm, Germany
Tel./Phone +49 731 9380688-0
Fax +49 731 9380688-50
info@phocos.com
www.phocos.com

Subject to change without notice.

Made in one of the following countries: Germany - China - Bolivia - India

Phocos AG - Germany